

# The Space

## **IMT200PEU** Clear Ice Maker



## **INSTRUCTION MANUAL**

## **Introduction**

Thank you for choosing our IMT200PEU clear ice maker! This brand-new product is designed to bulk produce clear ice in standard shapes, perfect for bars, restaurants, hotels and other businesses serving cold beverage. Compared with regular non-clear ice makers and traditional clear ice-producing processes, the IMT200PEU has the following advantages:

- Produce clear ice that is denser and melts more slowly than cloudy ice.
- Directly form clear ice in various sizes and shapes without cutting.
- Offers a one-touch, automated process for clear ice production.
- Solve long-term needs for clear ice and reduce cost.

With a sleek design and rigorous testing for safety and performance, we're confident the IMT200PEU will provide an outstanding user experience.

## **Disclaimer**

Before use, please carefully read this user manual. This manual provides all safety instructions related to the machine and is intended to provide qualified personnel with the information required for the proper installation, operation, and maintenance of the machine. It is essential to strictly follow the instructions in the manual when using the machine. Our company shall not be held responsible for any consequences resulting from failure to operate in accordance with the instructions provided.

# Contents

Important Safety Instructions.....	3
Package and Transportation .....	5
Product Structure .....	8
Specifications.....	10
Specifications for the Inlet and Outlet Pipe .....	11
Product Features.....	12
Operation Instructions.....	13
Before using.....	13
<b>How to clean</b> .....	16
<b>Selecting the ice making program</b> .....	16
How to make clear ice.....	17
How to use Freeze mode.....	24
Care and Maintenance.....	24
Troubleshooting .....	25
COMPLIANCE.....	28
WARRANTY INFORMATION.....	29
WARRANTY CARD.....	29

## Important Safety Instructions

- Only the power supply specified on the machine nameplate can be used with this machine.
- Outlet for this machine must meet the national laws and regulations and must be reliably grounded with leakage protection.
- Wear gloves when performing maintenance on the motor and the cooling system inside the machine.
- Do not insert a screwdriver or other device into the protective grilles, where there are heat exchange vents, evaporators, etc.
- Do not touch live parts with wet hands or bare feet.
- Do not block the heat exchange vents of the compressor or evaporator to ensure the normal operation of the machine.
- When opening or closing the lid, always hold the lid to avoid getting your hands caught.
- Do not place non-food items in the machine except the accessories that come with the machine.
- Only trained operators are allowed to use this machine.
- The installation, repair or maintenance of this machine must be carried out by professional and qualified personnel.
- The machine is not intended for use by children, persons with reduced physical, sensory or mental capabilities or lack of experience and knowledge.
- The machine should be properly managed to ensure that children will not play with or around it.
- If the power supply device of the machine fails, contact professional personnel certified by the manufacturer to replace it to avoid safety accidents.
- It is prohibited to modify or remove the provided safety devices (protective grilles, hazard labels, etc.) and the manufacturer is not responsible for the consequences of violating this instruction.
- In the event of a fire, use a carbon dioxide fire extinguisher instead of water, and cool the motor room as soon as possible.
- Do not use mechanical devices or other means to accelerate the defrosting process, other

than those recommended by the manufacturer.

- Do not damage the refrigerant circuit.
- Do not use other electrical appliances in the machine, unless they are recommended by the manufacturer.
- Refrigerants and blowing agents are flammable and should only be disposed of by qualified personnel and institutions.
- If the power cord is damaged, it must be replaced by the manufacturer, service agent, or qualified personnel.
- Do not store explosive substances such as aerosol cans with a flammable propellant in this machine.
- Keep clear of obstructions to all ventilation openings of the machine.
- Before performing any operation, unplug the power cord and ensure that the operator can check from any direction that the power cord is disconnected.
- The A-weighted emission sound pressure level is below 70 dB(A).
- The climatic class numbers marked on the machine nameplate indicate:
  - Maximum ambient temperature for appliances with climatic class 0, 1, 2, 3, 4, 6, or 8 in the test room:  $89.6^{\circ}\text{F} \pm 0.6^{\circ}\text{F}$ .
  - Maximum ambient temperature for appliances with climatic class 5 or 7 in the test room:  $109.4^{\circ}\text{F} \pm 0.6^{\circ}\text{F}$ .



Warning: risk of fire / flammable materials

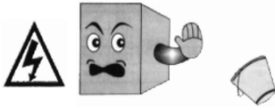

Watch out for electrocution.

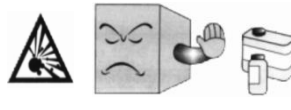

Attention to rupture

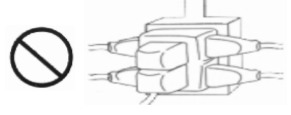
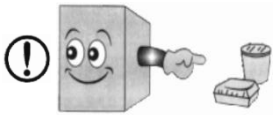

Ban



Contact prohibition



Watch out for spinners.

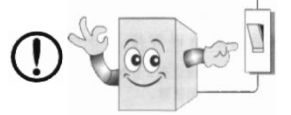

## Package and Transportation

- Packed in wood crates, the machine should be transported with appropriate equipment, do not move it with bare hands.
- When using a lifting system, such as forklifts or pallets, pay special attention to balance and prevent tipping.
- Normally, the machine should be fixed on wooden pallets to ensure safety during transportation and storage.
- Warning signs should be printed on the package to remind users to follow the instructions and ensure the machine will not be damaged during loading, unloading, and transportation.

Fragile



Upward



Do not flip

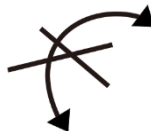

Keep dry



### Stacking limit

- When storing or moving the machine, the maximum stack is two units, unless otherwise

specified on the label.

- Since the center of gravity of the machine does not coincide with the geometric center, be careful not to tilt the machine during handling.

## **Unpacking**

- Please use tools for unpacking the wood crate. After the unpacking, if any damage is found, please inform the carrier immediately.

## **Installation**

- Install and place the machine securely on a stable and level surface.
- When handling, do not push or pull the machine to avoid tipping over or damaging the parts.
- Do not place any objects on the machine, as it is open from the top.
- The machine should be placed in a well-ventilated place, and away from heat and ignition sources.
- The minimum clearance  $\geq 100\text{mm}/3.9\text{"}$  should be kept between the surrounding of the machine and the wall or objects to ensure good operation performance, ventilation and maintainability.
- Before connecting to the power supply, make sure that the voltage and frequency are consistent with the machine nameplate. A variation of  $\pm 10\%$  of the normal voltage is allowed, and the machine should be connected to an effective ground connection.



## **Storage**

- Turn off the power and unplug the machine
- Empty the cabinet and clean it
- Keep the lid slightly open to ensure ventilation and avoid mildew or odors

## **Disposal**

- Temporary storage of special wastes may be permitted before disposal or final disposal.
- In all cases, the applicable environmental laws of the user's country must be complied

with.

	Correct disposal of this product
 	<p>This symbol indicates that this product should not be disposed of with other household waste. To prevent potential harm to the environment or human health from improper waste disposal, recycle it responsibly to promote sustainable material resource use. To return your used product, use the return and recycling system or contact the retailer where the product was purchased for environmentally safe recycling.</p>

# Product Structure

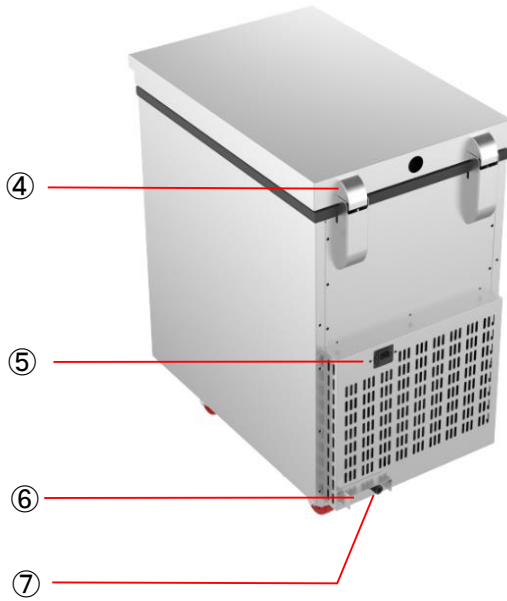
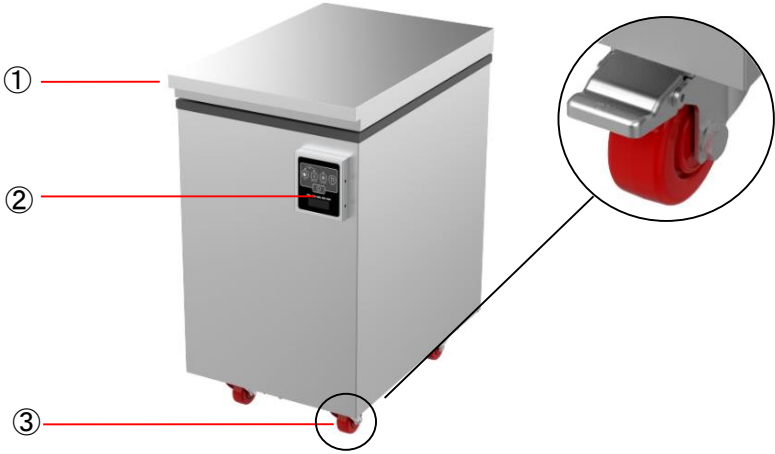

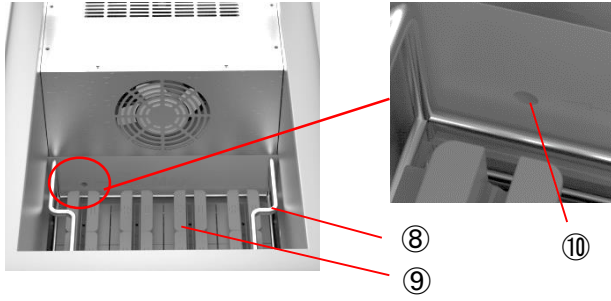

---

⑧+⑨ :

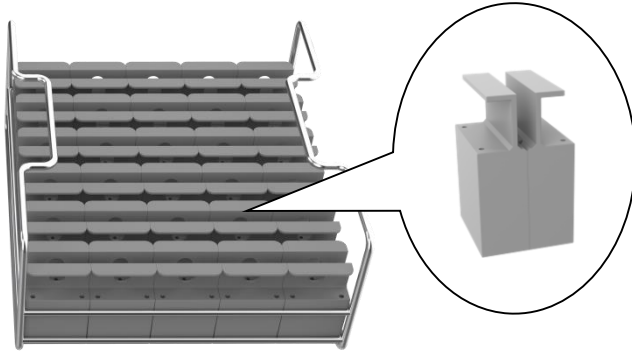

- ①Lid   ②Control panel   ③Universal wheels   ④Hinge   ⑤Power port  
⑥Drain pipe   ⑦Inlet pipe   ⑧Ice mold tray   ⑨Ice mold   ⑩Overflow hole

## Specifications

Model	IMT200PEU
Power supply	220-240V 50Hz
Ice-making power	350W
Ice-detaching power	700W
Exterior material	Stainless steel SUS201 with brushed finishes
Interior material	Stainless steel SUS304
Exterior dimensions	18.5" x 29.7" x 33.7" (470 × 755 × 856mm)
Interior dimensions	13.8" x 15.0" x 17.8" (350 × 382 × 452mm)
Tray number	1
Tray material	Stainless steel SUS304
Ice mold material	Food-grade silicone
Ice-making capacity (Customer-specified)	30 ice cubes
	16 large ice spheres
	25 small ice spheres
	24 ice bars
	30 ice diamonds
Single ice cube completion rate	Under normal operating conditions, when ice production is complete, the weight of a single ice cube is not less than 90% of the weight of the complete condensed ice cube.
Ice pattern translucency	Under normal operating conditions, the white mist appearing on the surface of each ice is less than 10% of the surface area of the ice. The appearance of air bubbles inside each ice is less than 10% of the volume of the ice sphere.
Ice production completion rate (for information only)	Under normal operating conditions, the number of ice cubes that meet the requirements of single ice cube completion rate and ice permeability accounts for more than 90% of the total number of ice cubes produced.
Ice size	Ice cube: 2.2 x 2.2 x 2.2 in (55 × 55 × 55 mm)
	Large ice sphere: Φ2.95 in (Φ75 mm)
	Small ice sphere: Φ2.36 in (Φ60 mm)
	Ice bar: 1.5 x 1.5 x 4 in (38 × 38 × 102 mm)
	Ice diamond: Φ2.4 x 2.2 in (Φ60 × 55 mm)
Weight	167.5 lb. / 76 kg (cube molds included)
	174 lb. / 79 kg (large sphere molds included)
	170 lb. / 77 kg (small sphere molds included)

	172 lb. / 78 kg (bar molds included)
	176 lb. / 80 kg (diamond mold included)
Temperature display unit	F / °C
Ice storage mode temperature	30.2 F (-1 °C)
Duration of ice storage	Ice storage time is recommended to be less than 4 hours, excessive storage time will affect the clarity and integrity of the ice.
Freeze mode temperature	5 F (-15 °C)
Working conditions	Temp: 41-90 F (5-32 °C), humidity: ≤85%

### Specifications for the Inlet and Outlet Pipe

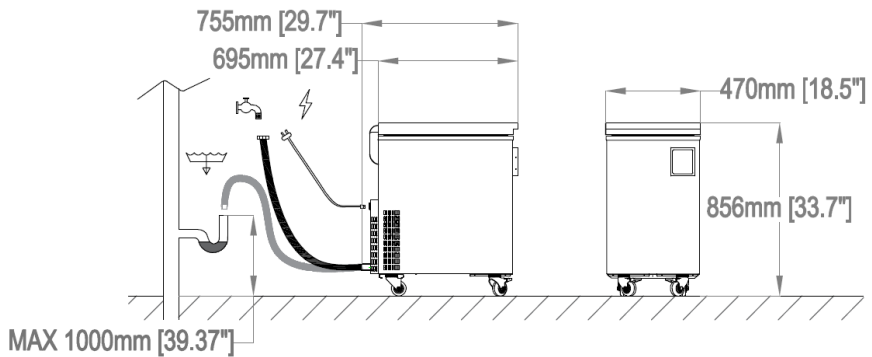

Inlet water pressure	Bar	0.2 to 8
Flow Rate	L/Min	5
Water inlet temperature	°C	≤35
	°F	≤95
Water connection	BSP	1/2"
	dn	15
Drainpipe Diameter	mm	∅ 15*∅ 10
	inch	∅ 0.6*∅ 0.4
Water inlet pipe	inch	78.7
	m	2
Drain pipe	inch	78.7
	m	2
Water consumption per cycle	L	30

# Product Features

Control panel:

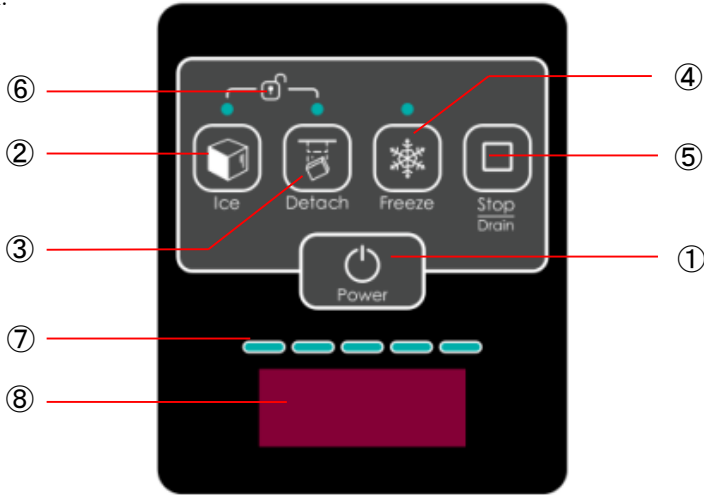

No.	Part	Description
1	Power	<p>--- Plug in the machine, and the display will show "OFF", and enter standby mode. Press the "Power" button to enter pre-operating mode, showing "ON".</p> <p>--- In pre-operating mode "ON" or during operation, pressing the power button can return to standby mode "OFF".</p> <p>---When the display shows "OFF," press and hold the "Power" button for 3 seconds to enter the program selection. Use short presses to switch between two programs ("1" or "2"). To exit this mode, press and hold the power button for 3 seconds. Refer to the "Operation Instructions" for program details.</p>
2	Ice	<p>--- In pre-operating mode "ON", press the Ice button, the indicator light is on, start the ice making mode:</p> <p>water filling (display ICE1, progress bar first lamp position blinking)</p> <p>→ Ice making (alternately displaying ICE3 and ice making time, progress bar third lamp position blinking)</p> <p>→ De-icing (display ICE4, Detach indicator light on, progress bar fourth lamp position blinking)</p> <p>→ complete ice making and enter the ice storage (display cabinet temperature, Ice and Detach indicator light off, progress bar all lamp positions light up). (ICE4 is displayed, Detach indicator light is off, progress bar fourth light position is blinking)</p> <p>→ Ice making is completed and the machine enters into ice storage (cabinet temperature is displayed, Ice and Detach indicator lights are off, all progress bar light positions are on).</p> <p>--- In pre-operating mode "ON", long press the Ice button for about 3 seconds, the</p>

		indicator light will be on, it will skip the water filling process, and directly enter the ice making process.
3	Detach	<p>--- During ice-making and in the unlocked state, pressing “Detach” button can enter ice-detaching mode in advance.</p> <p>--- In ice-storage status, press “Detach”, the machine will enter ice-detaching mode, and the indicator will turn on. When the ice-detaching is completed, the indicator will turn off and the display will show the temperature in the cabinet.</p>
4	Freeze	<p>--- In pre-operating mode “ON”, press the “Freeze” button, the indicator will turn on and the machine will enter freeze mode, with the display showing the cabinet temperature.</p> <p>--- In pre-operating mode “ON”, long press the button for about 3 seconds, then all lights of the progress bar will light up, and can re-enter ice storage status, in which the display will show the cabinet temperature.</p>
5	Stop/Drain	<p>--- During all working processes, pressing “Stop/Drain” will stop the task.</p> <p>--- In pre-operating mode “ON”, press and hold the “Stop/Drain” button for about 3 seconds to start the drainage process. The digital display will show "0000" or “dr”. Once the water has been completely drained, press the “Stop/Drain” button again to stop the drainage.</p>
6	Lock	After entering the Ice making process, the operation interface will be locked. If you need to perform other operations (such as ice-detaching or stopping the machine), you need to long press the "Ice" and "Detach" buttons for a few seconds to unlock. After unlocking, the machine will beep, and the display will show "Unlo".
7	Ice-making progress bar	Shows the ice-making progress. After ice-detaching, the whole progress bar will light up.
8	Display	<p>--- Shows ice-making stages, ice-making time, and cabinet temperatures.</p> <p>--- In standby mode, when the display shows "OFF," simultaneously press and hold the “Freeze” and “Stop/Drain” buttons for 3 seconds to switch the unit of ice storage temperature between Fahrenheit (°F) and Celsius (°C). In ice storage mode, if the last digit on the display shows "C," it indicates the current unit is Celsius (°C), and if it shows "F," it indicates the current unit is Fahrenheit (°F).</p>

## Operation Instructions

The following pictures are for illustrative purposes only, due to the different versions of the machine, the pictures may be different from the actual, all structures please prevail in kind.

### Before using

1. Place the machine on a stable, flat surface, ensuring nothing is under the machine to allow for proper heat dissipation. Keep at least 100mm/3.9in of space between the machine and any walls or objects for proper ventilation.

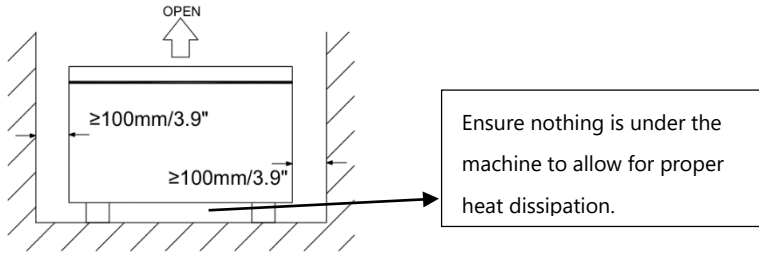

2. Connect the inlet pipe of the machine to the water supply and the drainpipe to the drainage system. (To clean the machine and drain the water, press and hold the "Stop/Drain" button for about 3 seconds, and make sure that the machine inlet pipe is connected to the tap and the tap is on).

**Note:**

- ① The water pressure must be between 0.02 MPa (0.2 bar) and 0.8 MPa (8 bar). If the water pressure exceeds 0.78MPa(8bar), an appropriate pressure relief valve should be used. After connecting the water supply, keep the tap on.
- ② It is not recommended to use distilled water as the water source because it can affect the transparency of the ice. It is recommended to use mineral water or filtered tap water.

3. Identify the water drainpipe

<p>This end is connected to the drain, and wastewater enters the drain through this port.</p>		<p>This end is connected to the machine and wastewater is discharged from the machine through this port.</p>
<p>The drain hose is a tube of approximately 2 meters / 78.7 inch in length with a 2-point internal tooth connector at one end for connection to the machine; the other end, without a connector, is connected to the drainpipe.</p>		

4. Identify the water inlet pipe

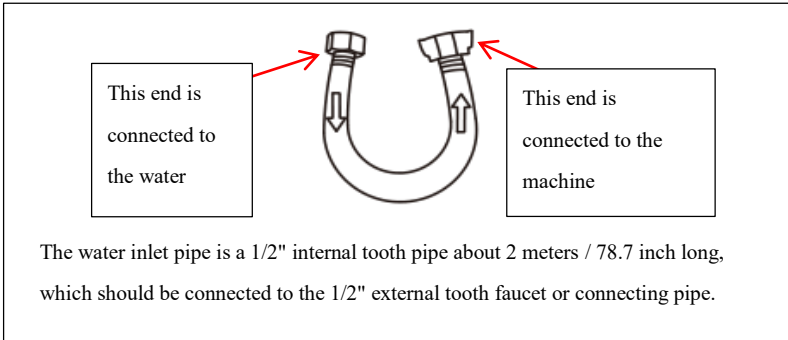

5. Install the drainpipe

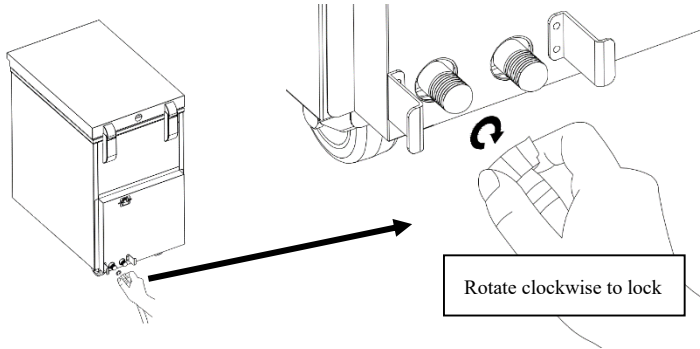

6. Install the inlet pipe

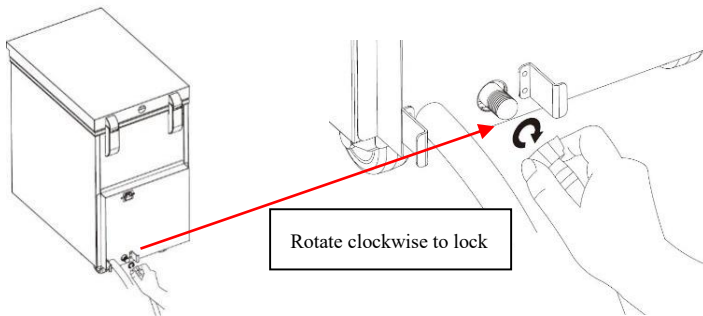

## 7. Diagram after installation

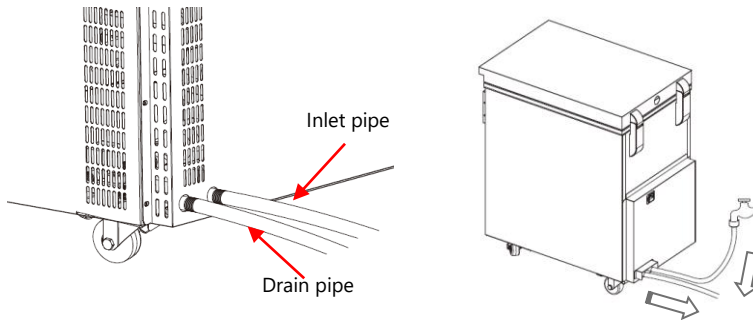

**Note: The drainpipe is a corrugated hose about 1 meter long and should be placed into the drainage system.**

### **How to clean**

Before first using, please clean the machine and drain the water by following the step 2 to 4. To maintain optimal ice-making efficiency, clean the machine's interior after each cycle and before starting a new one:

1. Clear any leftover ice fragments from the interior.
2. Plug in the machine. When the display reads "OFF," press the "Power" button to enter pre-operating mode "ON".
3. Hold the "Stop/Drain" button for about 3 seconds to initiate drainage; the display will indicate "0000" or "dr".
4. After the water has fully drained, press the "Stop/Drain" button again to stop the drainage, completing the cleaning process.

### **Selecting the ice making program**

By default, this machine operates in an environment with a temperature of 32°C/90°F or lower, corresponding to program number "1". If the temperature exceeds 32°C/90°F and you want better ice-making results, follow these steps to switch to program number "2":

1. Power on the machine, and the display shows OFF.
2. Hold down the Power button for 3 seconds until the display shows "1".
3. Press the Power button briefly to switch the display to "2".
4. After switching, hold down the Power button for 3 seconds to exit the program

selection, and the display shows OFF.

5. Setting is complete.

● **Note:**

- Program "1" has a 23-hour ice-making cycle.
- Program "2" has a longer 28.5-hour ice-making cycle for improved results.

### How to make clear ice

**NOTE:** Do not open the door body while the unit is running the ice making program or the ice making effect will be affected.

1. Fit the two halves of the molds together with the tongue and groove, and place them in the correct orientation within the tray.

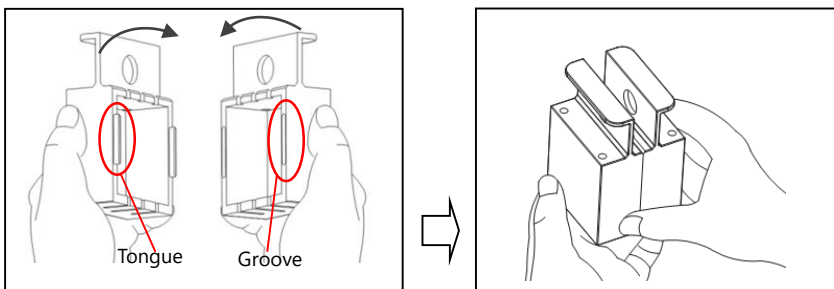

**Large ice sphere (  $\phi$  75mm):** Each tray can hold 16 large ice sphere molds. The ice molds are green, paired with trays marked with a circular symbol and the number 7. The orientation for placing the ice molds is as shown in the following diagram:

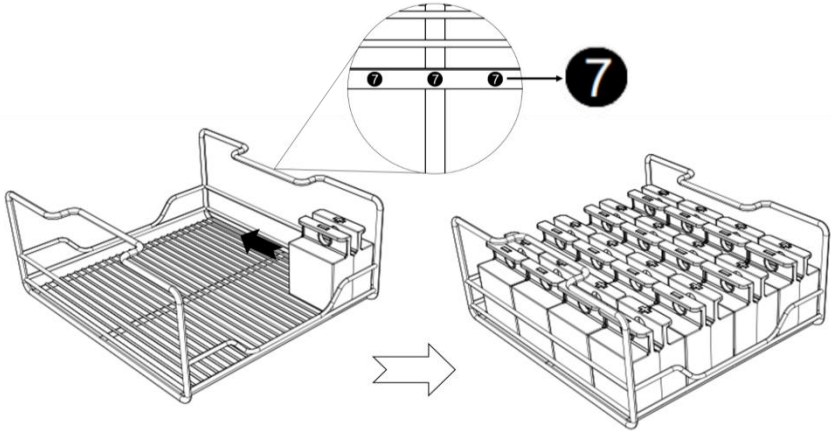

**Small ice sphere (  $\phi$  60mm):** Each tray can hold 25 small ice sphere molds. The ice molds are light green, paired with trays marked with a circular symbol and the number 6. The orientation for placing the ice molds is as shown in the following diagram:

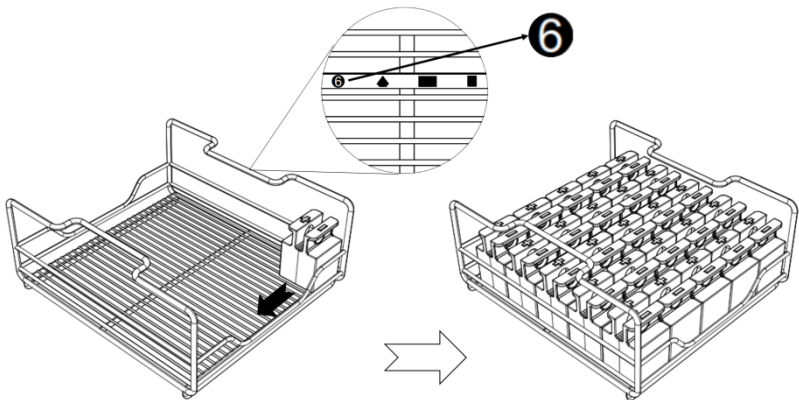

**Ice cube:** Each tray can hold 30 ice cube molds. The ice molds are grey, paired with trays marked with a square symbol. The orientation for placing the ice molds is as shown in the following diagram:

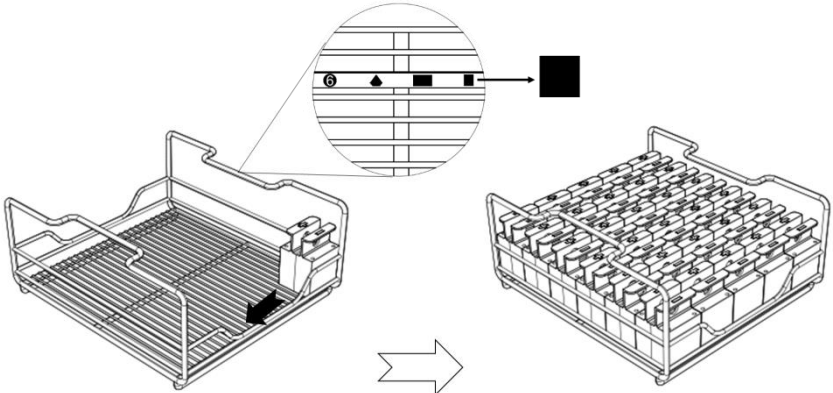

**Ice bar:** Each tray can hold 24 ice bar molds. The ice molds are black, paired with trays marked with a rectangular symbol. The orientation for placing the ice molds is as shown in the following diagram:

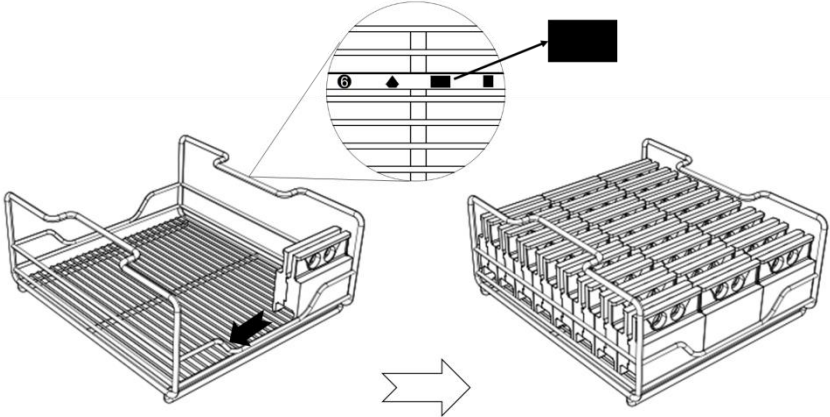

**Ice diamond:** Each tray can hold 30 ice diamond molds. The ice molds are purple, paired with trays marked with a diamond symbol. The orientation for placing the ice molds is as shown in the following diagram:

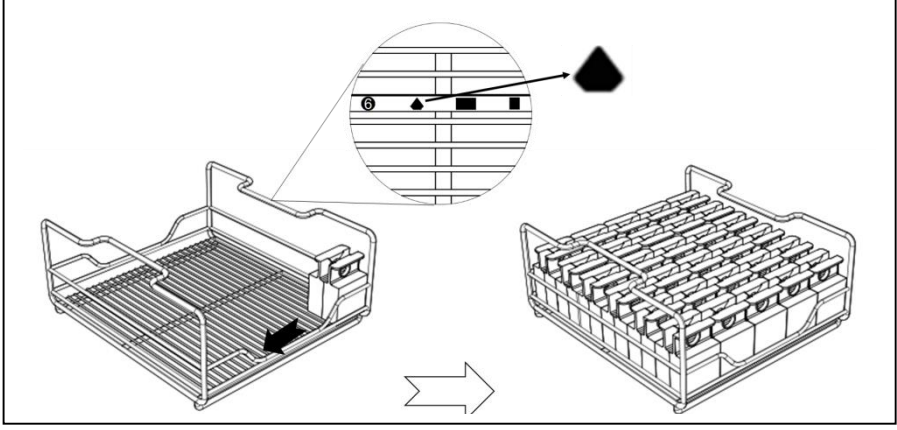

2. Place the tray with the molds on the support blocks in the machine.

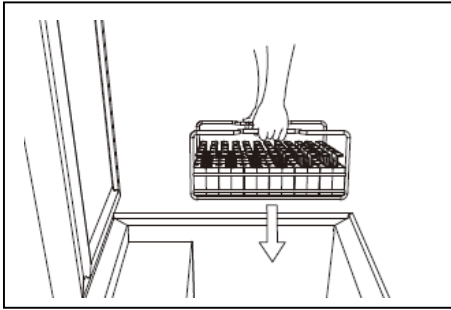

3. Close the lid.

**Note:** When opening or closing the lid, always hold it with your hand to avoid injury.

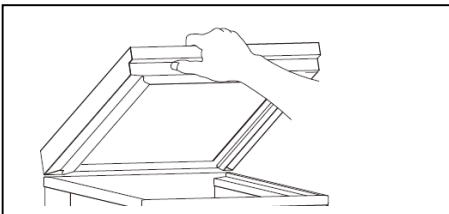

4. Connect to the power supply, and the display will show "OFF". Press the "Power" button,

and the machine will show “ON” and enter pre-operating mode.

5. Press the "Ice" button, the indicator light will turn on, and the machine will start to work:
  - a) The machine is first filled with water, the display shows “ICE1”, and the first indicator light of the progress bar flashes.
  - b) When the water-filling is complete, the first and second indicator light of the progress bar will keep on.
  - c) When the machine starts ice making, the display will show “ICE3” and ice-making time alternately. Meanwhile, the third light of the progress bar will flash.
  - d) When the ice-making is complete, the third light of the progress bar will keep on, and the machine will start detaching ice. The indicator of “Detach” will light up, the display will show "ICE4", and the fourth light of the progress bar will flash.
  - e) When the ice-detaching is complete, the “Ice” and the “Detach” indicators will be off, and the fourth and fifth lights of the progress bar will keep on. (All the lights of the progress bar will be on when the entire ice making process is complete.)

**Note:**

- **If for some reason, the machine cannot automatically fill with water, you can manually add water to the MAX line, and do not exceed the entire overflow hole. It is not recommended to use pure water. Filtered water or mineral water is recommended.**

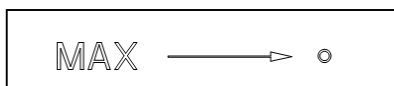

- **If you want to detach the ice in advance during ice-making process, first unlock the machine by pressing the “Ice” and “Detach” buttons simultaneously for several seconds. Then press "Detach" and the machine will start detaching ice.**
6. When the whole process is complete, all lights on the progress bar will be on, and the machine will make three beeps. The indicators of “Ice” and “Detach” will be off, the display will show the cabinet temperature, and the machine will enter ice storage mode.

**Note:**

- **After entering ice storage mode, if the machine stops (possibly caused by accidentally**

pressing "Stop/Drain" or "Power"), press and hold the "Freeze" button for about 3 seconds in pre-operating mode "ON", and the machine will re-enter the ice storage mode.

- In ice storage mode, the last digit on the display indicates the temperature unit. "C" represents Celsius, and "F" represents Fahrenheit. To switch the temperature unit, please follow these steps: First, press the "Stop/Drain" button to return to pre-operating mode "ON". Next, press and hold both the "Freeze" and "Stop/Drain" buttons for about 3 seconds to complete the unit switch. Lastly, press and hold the "Freeze" button for about 3 seconds to re-enter the ice storage mode.
- After entering the ice storage mode, the last digit of the digital tube is the temperature unit, C indicates Celsius (°C), and F indicates Fahrenheit (°F).
  - ◆ To switch the temperature unit, first press the "Stop/Drain" button to return to the pre-operating mode "ON".
  - ◆ Then press the "Power" button to let the machine go back to the standby mode "OFF".
  - ◆ After that, press and hold the "Freeze" and "Stop/Drain" buttons for 3 seconds to complete the unit switch.
  - ◆ Then press the "Power" button again to let the machine enter the pre-operating mode "ON".
  - ◆ Finally, press and hold the "Freeze" button for about 3 seconds to let the machine re-enter the ice storage state.

7. For ice removal, there are two methods: Method 1 is recommended when there is sufficient operating space, otherwise use Method 2.

- a) Method 1: Remove the tray and place it on a work surface for 15 minutes. Pull out the first ice mold from the indentation of the tray's edge, then continue with the others. Return the tray with any remaining molds to the machine for storage.

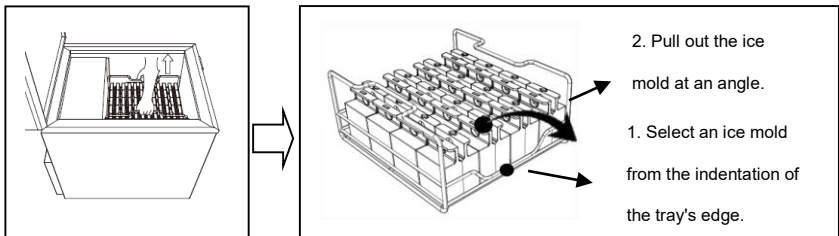

- b) Method 2: Without removing the tray, select and pull an ice mold near the tray's edge in the machine.

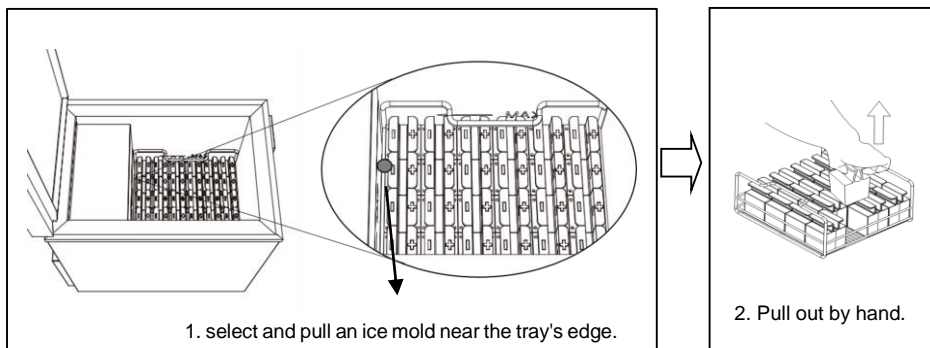

- c) If the ice molds are frozen together and cannot be pulled apart, use a tool like a chisel to clear surrounding ice and pry the molds loose.

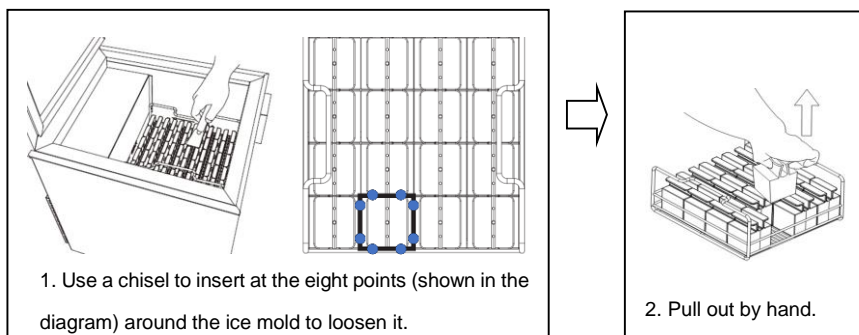

**Note:**

- i. After the machine is ice-detach, it will automatically switch to ice storage mode, but you still need to remove the ice cubes within 4 hours after ice-detach, otherwise the transparency of the ice cubes will be affected, and the ice cubes will melt.
- ii. The removed ice can be stored in the freezer, the recommended storage temperature is  $-5^{\circ}\text{C}$  to  $-18^{\circ}\text{C}$  ( $23^{\circ}\text{F}$  to  $-0.4^{\circ}\text{F}$ ). If the storage temperature is below  $-18^{\circ}\text{C}$  ( $-0.4^{\circ}\text{F}$ ), the ice cubes may crack if room temperature liquor is poured over them.

8. Open the ice mold and remove the ice.

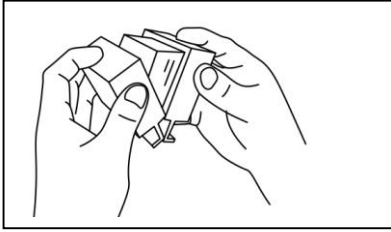

**Note:**

- a) If opening the ice mold is difficult, quickly dip it in clean water for about 1-2 seconds and then open it.
- b) Once the ice-making is done, there may be some ice columns or ice flakes remaining on the ice surface. These are formed around the water inlet of the ice mold, clear them by wiping or chiseling, and your clear ice will be good to go.
- c) While taking out the ice, actions like pulling or stretching may result in minor surface cracks. Typically, these cracks can be resolved by immersing the ice in a liquid.

### **How to use Freeze mode**

The machine comes with the Freeze mode for storing food at a temperature of around 5°F (-15°C). When using this mode, do not place the ice molds in the cabinet, but can leave the trays.

- Connect to the power supply, and the display will show "OFF". Press the "Power" button, and the machine will enter pre-operating mode "ON".
- 2. Press the "Freeze" button to start the freeze mode. The display will show the real-time internal temperature, which will be controlled at about 5°F (-15°C).
- 3. Place items in the cabinet and close the lid.

## **Care and Maintenance**

1. Unplug the machine before cleaning and maintenance.
2. Regularly clean the machine surface with a damp cloth to remove dust and dirt.
3. Regularly clean and disinfect the molds. It can be washed in a dishwasher and disinfected

in a sterilizer cabinet. It is recommended to clean them every 15 days or according to your using situation.

4. Regularly clean the cabinet and the trays with water. It is recommended to clean them every 15 days or according to your frequency of use.
5. Non-professionals should not disassemble or maintain the machine.
6. Do not tilt the machine when moving or transporting, otherwise it may be damaged.
7. The company will not be responsible for any damage or quality problems caused to the machine by users who do not operate the machine in accordance with this manual.

## **Troubleshooting**

### **Cannot start**

- Make sure the power cord is plugged into the power outlet.
- Check whether the power cord is damaged. If so, do not use the machine.
- If not for the above reasons, please contact professionals for maintenance. (The problem may be: the control panel is damaged, the wire connector is loose, etc.)

### **Cannot fill with water**

- Check whether the button has been pressed and whether the dash-line on the display is moving up and down.
- Make sure the connected water source is turned on.
- If the water inlet valve is faulty, or there is no power supply, please contact professionals for maintenance.

### **Cannot drain water**

- Try pressing and holding the "Stop/Drain" button for about three seconds in pre-operating mode "ON" to drain the water.
- Check whether the drain pipe is blocked.
- If the drain valve or the pump malfunctions, please contact professionals for maintenance.

### **Cannot make ice or refrigerate**

- When filling water, the overflow hole may be blocked by bubbles or other things. The water cannot overflow and the ice-making program cannot be started. Please clear the hole to make

water overflow smoothly.

- The water level switch may be damaged, so the water level cannot be sensed and the machine cannot start working. Please check to make sure the water level has reached the overflow hole level, then try to press and hold the "Ice" button for about 3 seconds to skip the water filling and go to the next step.
- The control panel and power panel may be damaged, or the wire connector may be loose, which requires professional maintenance.

### **Cannot detach ice**

- Try pressing and holding the "Detach" button for about 3 seconds in pre-operating mode "ON" to start the ice-detaching process again.
- The control panel and power panel may be damaged, or the wire connector may be loose, which requires professional maintenance.
- Water heating and circulation may damage or loosen the power terminals or others, which requires professional maintenance.

### **Time or temperature inaccurate**

- The control panel, power panel, and temperature sensor may be damaged, or the wire connector may be loose, which requires professional maintenance.

### **Unsatisfactory ice-making results**

- If the ice produced is opaque and contains many bubbles, adding baking soda during ice making can increase its transparency.
  - Before making ice, add 7.5g / 0.26 oz of baking soda to the bottom of the machine's chamber.
  - Then place the mesh frame and silicone ice tray.
  - Next, start the machine and press the "ICE" button to let the machine automatically fill with water and make ice.
  - Do not add baking soda to the water surface after the machine fills with water, as the baking soda will not disperse and will cause the ice cubes to taste bitter.
- Reach out to customer service or sales personnel for after-sales support.

## Error Codes

Code	Problem	Solution
H2O	Water filling exceeds 3 hours, and the water level switch is not triggered.	<ol style="list-style-type: none"> <li>1. The water pressure may be too high so the water inlet valve cannot be opened; or the water pressure is too low and the water level in the cabinet cannot reach the overflow hole within 3 hours. Please try to manually add water to the MAX line to see if the machine can operate.</li> <li>2. May be caused by the water inlet valve or water level switch failure, which requires professional maintenance.</li> </ol>
LP	<p>During the ICE3 ice-making and ICE4 ice-detaching processes, if there is a sudden power failure and power is restored, it will display "LP."</p> <p>In the case of a power interruption during the ICE1 water filling or ice storage process, upon power restoration, it will display "OFF" and not show "LP."</p>	<ol style="list-style-type: none"> <li>1. Lift the lid to check if the cabinet is freezing.</li> <li>2. If the cabinet has not frozen yet: <ol style="list-style-type: none"> <li>a) Press "Ice" or "Stop/Drain" to exit the "LP" display.</li> <li>b) Press "Ice" again to continue the ice-making.</li> </ol> </li> <li>3. If the cabinet is frozen: <ol style="list-style-type: none"> <li>a) Press "Ice" or "Stop/Drain" to exit the "LP" display.</li> <li>b) Press "Detach" to defrost, take out all the ice molds after the ice-detaching.</li> <li>c) Hold down "Stop/Drain" for 3 seconds; the display will flash "0000" or "dr" to drain any remaining water.</li> <li>d) Place the ice molds back in and press "Ice" to start the ice-making again.</li> </ol> </li> </ol>

### **Thank you for choosing our clear ice maker!**

We hope you enjoy using it. If you have any questions while using the product, feel free to reach out to us.

Brand Owner: ADVANCED CUISINE TECHNOLOGY PTE.LTD.

Brand Owner Address: 60 Paya Lebar Road, #11-19 Paya Lebar Square, Singapore 409051

Brand Owner Website: [www.thespacetec.com](http://www.thespacetec.com)

# COMPLIANCE

The parts of our product have undergone strict product testing in order to comply with regulatory standards and specifications set by international, independent, and federal authorities.

Our products have been approved to carry the following EU Marks:

Electromagnetic Compatibility Directive 2014/30/EU

EN IEC 55014-1:2021

EN IEC 55014-2:2021

EN IEC 61000-3-2:2019+A1:2021

EN 61000-3-3:2013+A1 :2019+A2:2021



# WARRANTY INFORMATION

Our products come with a 2-year limited warranty. Warranty replacements are eligible within 2 years of the original date of purchase. To be eligible for a warranty replacement, you must:

Have purchased the product within the last 2 years.

Have the original order number, or email that was used during your purchase. If purchased through a reseller, retail partner, or other website, you must provide a copy of your original receipt.

\*\* Email us to request warranty service: \_\_\_\_\_ \*\*



# WARRANTY CARD

\*\* Email us to request warranty service: \_\_\_\_\_ \*\*

Customer Name \_\_\_\_\_

Address \_\_\_\_\_

City/State/Zip \_\_\_\_\_

Telephone Number \_\_\_\_\_

E-Mail Address \_\_\_\_\_

Original Date of Purchase \_\_\_\_\_

Product Model No. \_\_\_\_\_

Serial No. (If Applicable) \_\_\_\_\_

Merchant's name \_\_\_\_\_